



(Following Paper ID and Roll No. to be filled in your Answer Book)

PAPER ID : 140502

Roll No.

--	--	--	--	--	--	--	--	--	--

B. Tech.

(SEM. V) (ODD SEM.) THEORY
EXAMINATION, 2014-15
THEORY OF MACHINES - I

Time : 3 Hours]

[Total Marks : 100

1 Attempt any **FOUR** parts of the following : **5x4=20**

- a) Deduce the expression for the friction moment of a collar thrust bearing, stating clearly the assumption made.
- b) Briefly explain the following :
 - I Slip of the belt
 - II Creep of the belt.
- c) An effort of 1200 N is required to just to move a certain body up an inclined plane of angle 12° with force acting parallel to the plane. If the angle of inclination is increased to 15° , then the effort required is 1400 N. Find the coefficient of friction and the weight of the body.
- d) A shaft has a number of collars integral with it. The external diameter of the collars is 400mm and the shaft diameter is 250mm. If the uniform intensity of pressure is 0.35N/mm^2 and its coefficient of friction is 0.05, estimate power absorbed in overcoming friction when the shaft runs at 105 rpm and carries a load of 150KN.

- e) What is meant by self locking and self energized brake?
 f) Two parallel shafts 6 m apart are provided with 300 mm and 400 mm diameter pulleys and are connected by means of a cross belt. The direction of rotation of the follower pulley is to be reversed by changing over to an open belt drive. How much length of the belt has to be reduced?

2 Attempt any **TWO** parts of the following : **10x2=20**

- a) Sketch slider crank chain and its various inversions, stating actual machines in which these are used in practice.
 b) State and prove the 'Aronhold Kennedy's Theorem' of three instantaneous centres.
 c) The crank and connecting rod of a theoretical steam engine are 0.5 m and 2 m long respectively. The crank makes 180 rpm in the clockwise direction. When it has turned 45° from the inner dead centre position, determine:
 a) Velocity of piston b) Angular velocity of connecting rod. c) Velocity of point E on the connecting rod 1.5 m from the gudgeon pin. d) Velocity of rubbing at the pins of the crank shaft, crank and crank cross head when the diameters of their pins are 50mm and 60mm and 30mm respectively.

3 Attempt any **TWO** parts of the following : **10x2=20**

- a) Give a neat sketch of the straight line motion Hart mechanism. Prove that it produces an exact Straight line motion.
 b) Two shaft are connected by a Hooke's Joint. The driving shaft revolves uniformly at 500 rpm. If the total permissible variation in speed of the driven shaft is not to exceed $\pm 6\%$ of the mean speed, find the greatest permissible angle between the centre line of the shafts.

- c) In a Whitworth quick return motion, as shown in FIG 1. OA is a crank rotating at 30 revolutions per minute in a clockwise direction. The dimensions of various links are OA = 150mm; OC = 10mm; CD = 125mm; and DR = 500mm. Determine the acceleration of the sliding block R and the angular accelerating of the slotted level CA.

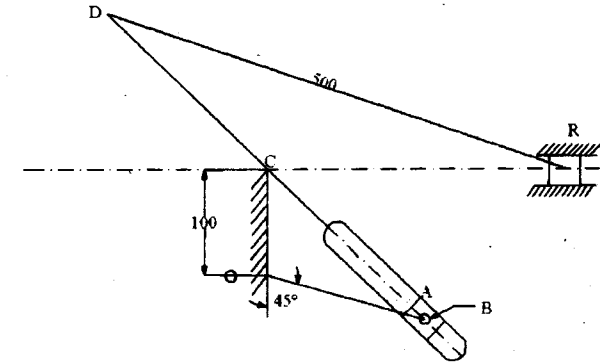

FIG 1

4 Attempt any **TWO** parts of the following : **10x2=20**

- a) Draw the profile of a cam operating a knife-edge follower when the axis of the follower is offset 20 mm towards right from cam axis from the following data.
 i. Follower to move outwards through 40 mm during 60° of cam rotation.
 ii. Follower to dwell for the next 45°
 iii. Follower to return to its original position during next 90°
 iv. Follower to dwell for the rest of the cam rotation.
 The displacement of the follower is to take place with SHM during both the outward and the return strokes. The least radius of cam is 50 mm. If the cam rotates at 300 rpm, determine the maximum velocity and acceleration of the follower during the outward stroke and return stroke.

- b) What is tangent cam? Find the expression for the velocity and acceleration of a roller follower for such a cam.
- c) Explain with sketches the different types of cams and followers.

5 Attempt any **TWO** parts of the following : **10x2=20**

- a) Two mating gears have 20 and 40 involute teeth of module 10 mm and 20° pressure angle. If the addendum on each wheel is such that the path of contact is maximum and interference is just avoided, find the addendum for each gear wheel, path of contact, arc of contact and contact ratio.
- b) Prove that the maximum length of arc of contact between a pair of gear tooth to avoid interference is $(r+R) \tan \phi$.
- c) In an epicyclic gear train, as shown in FIG 2 , the number of teeth on wheels A, B and C are 48, 24 and 50 respectively. If the arm rotates at 400 r.p.m., clockwise, find: 1. Speed of wheel C when A is fixed, and 2. Speed of wheel A when C is fixed.

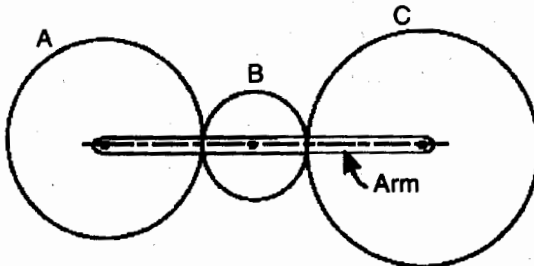

FIG 2